

LITTLE GIANT

Power Forging Hammers

2020 Parts Catalog

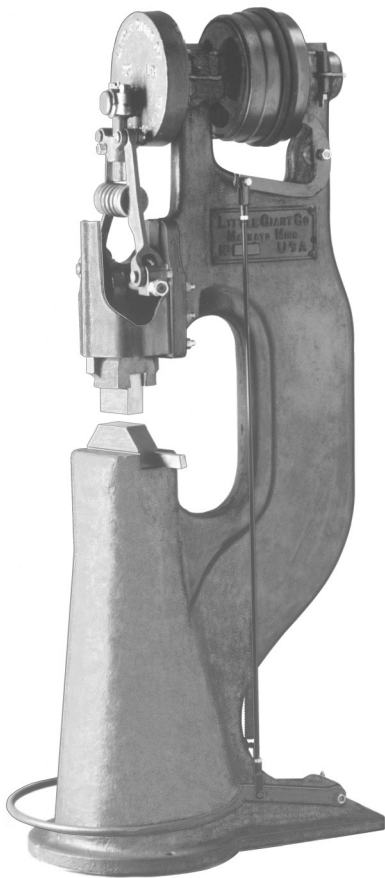

Old Style

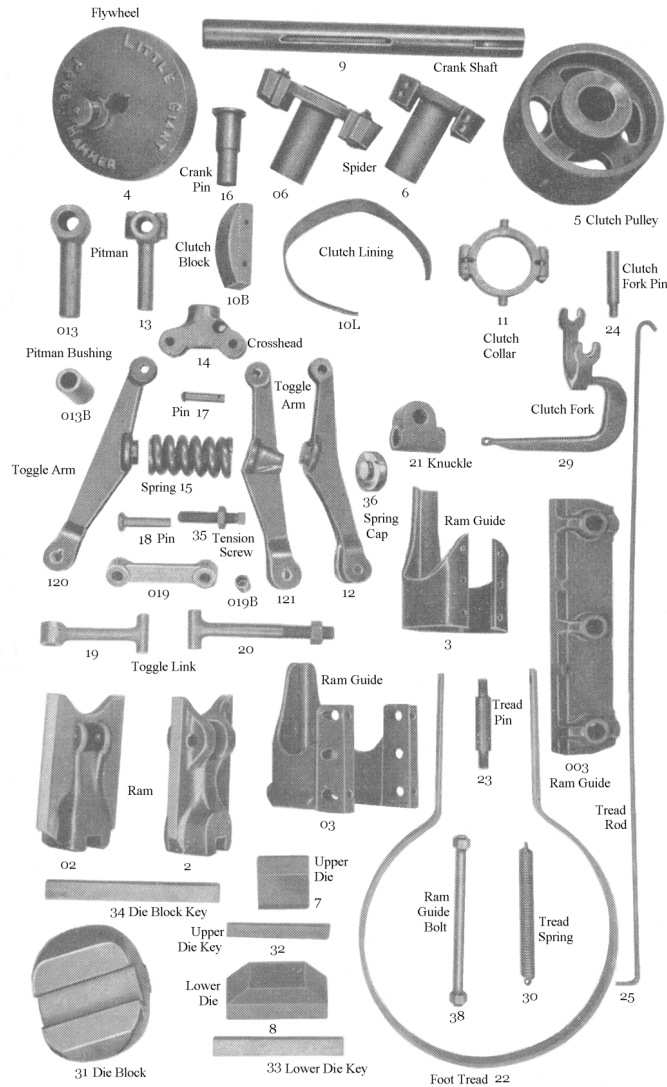

New Style

Parts---Repairs---Information

6414 King Road

Nebraska City, NE 68410

402.873.6603

(Website): LittleGiantHammer.com

(Email): mm21654@gmail.com

Little Giant Rebuilding DVD

See last page for details.

FOB Nebraska City, NE

We accept Visa, MasterCard, Discover, American Express, UPS-COD, prepayment by check.

Prices are subject to change.

Are these authentic Little Giant parts?

99% of our parts are made from the original Little Giant blueprints and foundry patterns.

Is my machine a Little Giant?

If the flywheel says “Little Giant” or “Mankato, Minn”, it is a Little Giant. Some Little Giants will not say “Little Giant” anywhere on the machine, just “Mayer Bros”. As long as the machine says “Mankato, MN” on the flywheel it is a Little Giant. If a power hammer was made in Wisconsin or Canada, it is not a Little Giant. We do carry a very limited number of parts for the Mayer hammers made in Wisconsin (page 6). Some Little Giant parts will work on Canadian Giants.

How do I tell what size of Little Giant I have?

The easiest way to determine the size of a Little Giant is to read the flywheel. Often, but not always, the size is cast there. The second place to identify size is looking at the serial number. The serial number is a 2 to 4 digit number, usually stamped or cast on the side of the frame. The number is usually preceded by a letter, which stands for the size of the hammer. Some of the individual parts may have letters and numbers cast on them. On very early 50 LB Little Giants, the serial number may be stamped on the spine of the frame or on the cast-in ram guide.

H	25LB		S	250LB
K	50LB		T	500LB
P	100LB		E	(Easy)

Sometimes, none of the above will help. In that case, use the information below to determine the size.

Useful Information

Hammer Size	25LB	50LB	100LB	250LB	500LB	Easy 30LB
Die Height	3" ea.	3-1/2" ea.	4" ea.	5" ea.	6" ea.	3"
Shaft Size	1-5/8	2"	2-1/2"	3-1/4"	4"	1-3/4
Clutch Pulley Clearance	.008-.012	.012-.016	.014-.018	.016-.020	.020-.030	
Flywheel Dia.	10"	13"*	16"	24"	32"	14"
Motor HP & RPM	1HP 1725RPM	2HP 1725RPM	5HP** 1725RPM	7-1/2HP 1155 RPM	15HP	2HP 1725RPM
Clutch Pulley size	10" (13")	12" (15")	14" (21")	18" (28")	24-1/2" (35")	12"
Motor Pulley Size	3" (3-1/4")	3-1/4"	3-1/2" (4-1/4")	(5-1/4")	(5.5")	3-1/4"
Speed Rpm	275-375	250-325	225-275	150-190	140-160	250-325
Hammer Weight (LBS)	900	1800	3400	6000	12000	1000
Forging Capacity	2"Rnd.	3"Rnd.	4"Rnd.	6"Rnd.	7"Rnd.	2.5 Rnd.

*Some very early 50 LB Little Giants have a 15" flywheel

**Original recommendation was 3 HP; we find 5 HP yields better performance

About that serial number....

The original Little Giant factory kept handwritten records of every machine they sold. If you would like to know the history of your Little Giant, contact us and we will share this information with you. The records always list a date of sale, often the individual buyer's name and location, and usually the wholesaler name.